

GT4094R

Displacement 2.0L - 6.0L

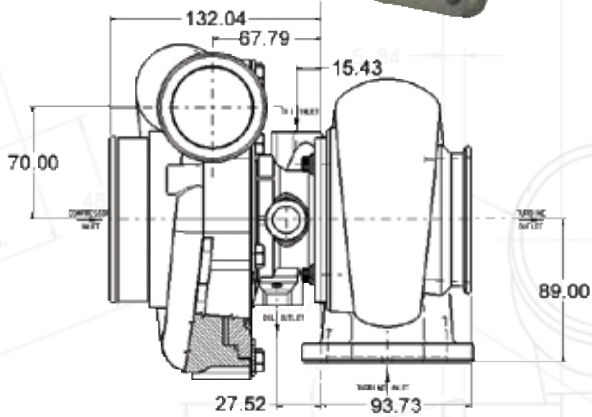

HORSEPOWER 450 - 800

2000
1900
1800
1700
1600
1500
1400
1300
1200
1100
1000
900
800
700
600
500
400
300
200
100
0

- Dual ball bearing, oil & water-cooled CHRA
- Free float, non-wastegated turbine housing
- Ideal for applications that cannot accommodate the GT4294R but need more flow than the GT4088R
- Outline interchangeable with the GT4088R

GT4094R		COMPRESSOR				TURBINE		
Turbo PN	CHRA PN	Ind Whl Dia	Exd Whl Dia	Trim	A/R	Whl Dia	Trim	A/R
751470-19	751450-16	67.8mm	94.0mm	52	0.72	77.0mm	78	0.85
751470-20	751450-16	67.8mm	94.0mm	52	0.72	77.0mm	78	0.95
751470-21	751450-16	67.8mm	94.0mm	52	0.72	77.0mm	78	1.06
751470-22	751450-16	67.8mm	94.0mm	52	0.72	77.0mm	78	1.19

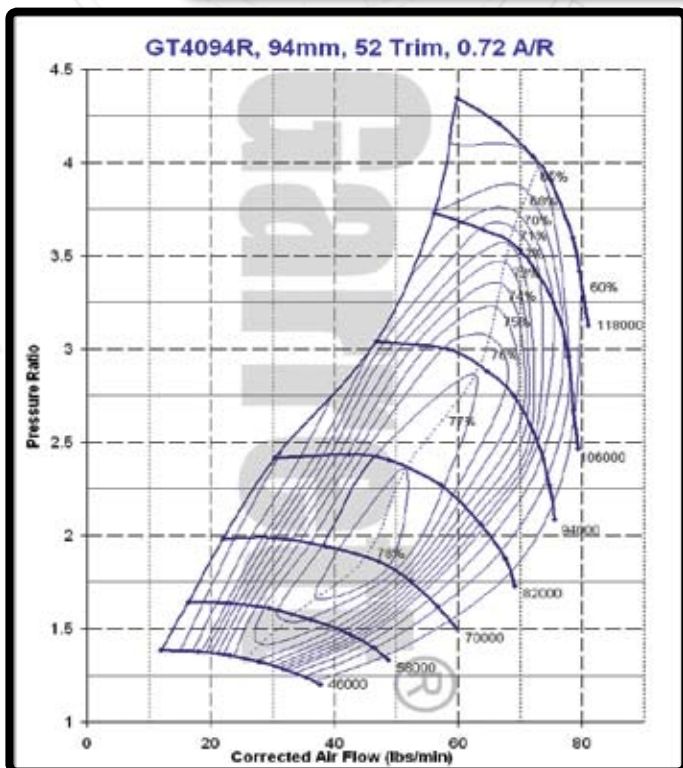

TURBINE HOUSING OPTIONS			
PN	Whl Dia	Trim	A/R
448375-18	-	-	0.85
448375-19	-	-	0.95
448375-20	-	-	1.06
448375-21	-	-	1.19

