

# Garrett®

by Honeywell

## GT2052

Displacement 1.4L - 2.0L



**HORSEPOWER 140 - 225**

- Journal bearing, oil-cooled CHRA
- Internally wastegated turbine housing, complete with actuator
- Two orientations available

2000  
1900  
1800  
1700  
1600  
1500  
1400  
1300  
1200  
1100  
1000  
900  
800  
700  
600  
500  
400  
300  
200  
100  
0

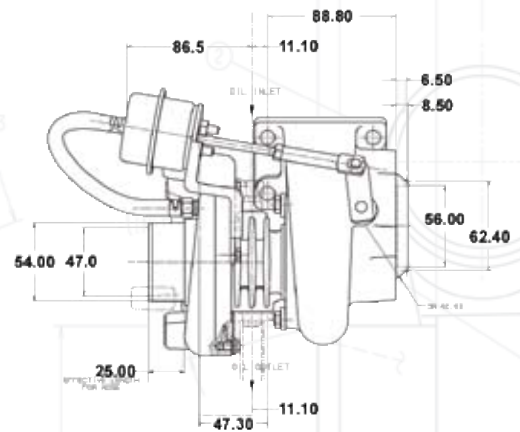

GT2052		COMPRESSOR				TURBINE		
Turbo PN	CHRA PN	Ind Whl Dia	Exd Whl Dia	Trim	A/R	Whl Dia	Trim	A/R
727264-4	451298-45	36.8mm	52.0mm	50	0.51	47.0mm	72	0.50
727264-5	451298-45	36.8mm	52.0mm	50	0.51	47.0mm	72	0.50

Dimension Note:  
Oil Inlet: Both PN - M10x1.0 (F) or M10x1.0 (M)

