

GT1241

Displacement 0.4L - 1.2L

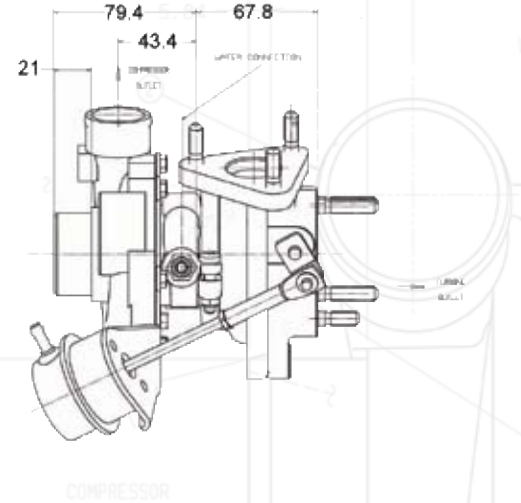

HORSEPOWER 50-130

- Journal bearing, oil & water-cooled CHRA
- Smallest Garrett® turbocharger available
- Excellent for motorcycles or other small displacement engines
- Internally wastegated turbine housing, complete with actuator

2000
1900
1800
1700
1600
1500
1400
1300
1200
1100
1000
900
800
700
600
500
400
300
200
100
0

GT1241		COMPRESSOR				TURBINE		
Turbo PN	CHRA PN	Ind Whl Dia	Exd Whl Dia	Trim	A/R	Whl Dia	Trim	A/R
756068-1	757864-1	29.0mm	41.0mm	50	0.33	35.5mm	72	0.43

